

LEFT SIDE VIEW

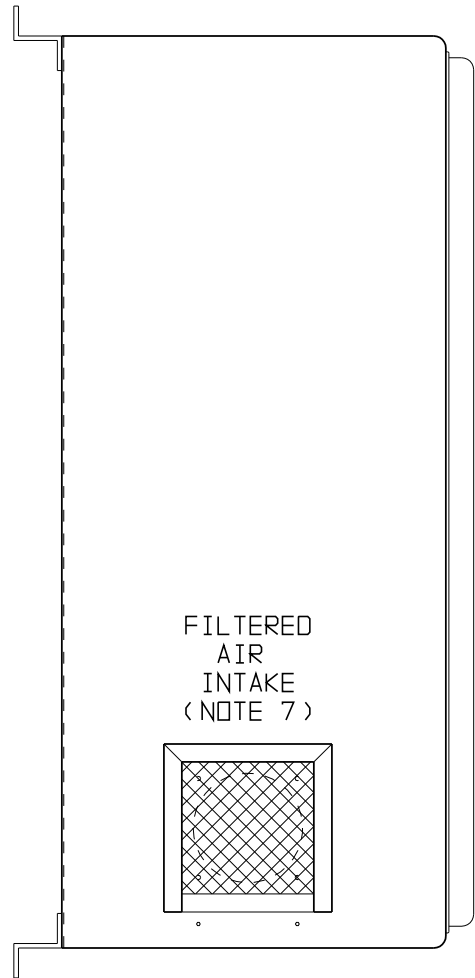

FILTERED AIR INTAKE (NOTE 7)

FRONT VIEW

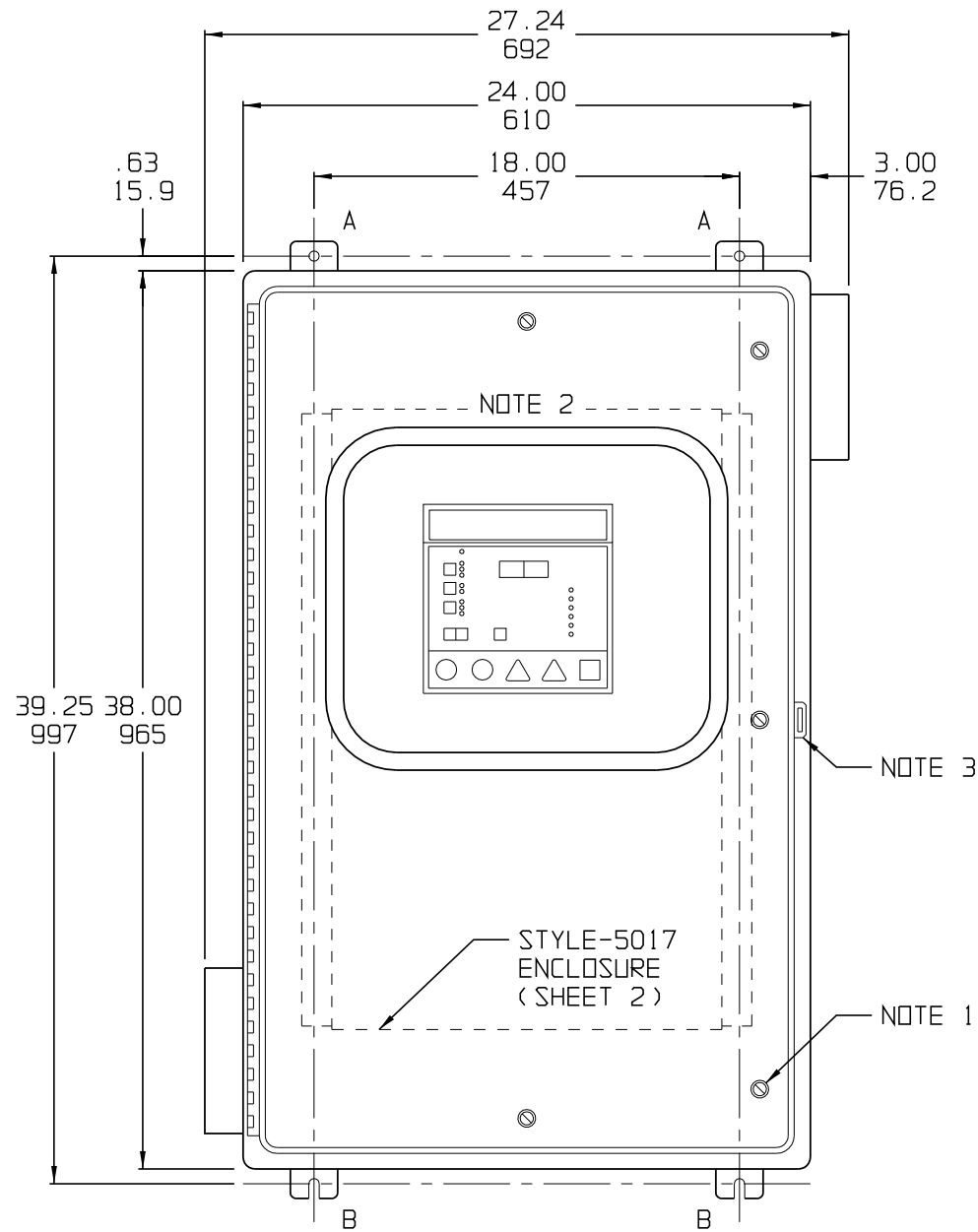

NOTE 2

STYLE-5017 ENCLOSURE (SHEET 2)

NOTE 3

NOTE 1

NOTE 6

NOTE 5

BOTTOM VIEW

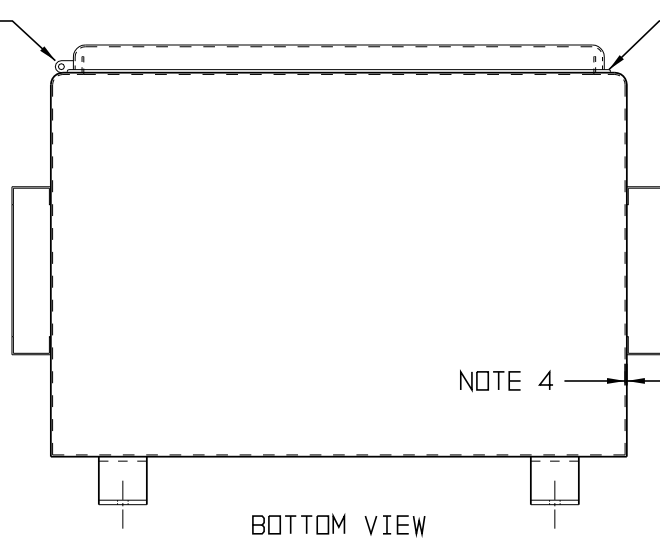

NOTE 4

RIGHT SIDE VIEW

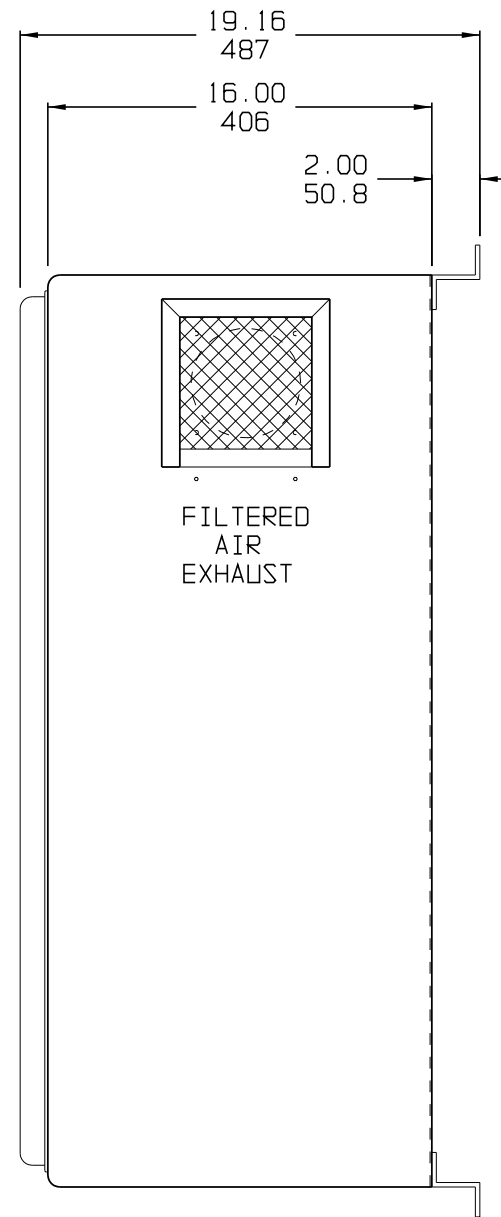

FILTERED AIR EXHAUST

HOLE	DIA.	QTY.	APPLICATION
A	0.438 11.11	2	WALL MOUNTING HOLES
B	0.438 11.11	2	WALL MOUNTING SLOTS

NEMA-4/12/13 ENCLOSURES FEATURE NO PRE-FABRICATION PROVISIONS FOR CONDUIT ENTRANCE. CABINET SHOULD BE FIELD-MODIFIED BY INSTALLER AS NEEDED FOR I/O.

NOTES:

- 1) CHROME-PLATED, 1/4-TURN, SLOTTED LATCHES SUPPLIED TO MEET NEMA TYPE 4 / IP66 STANDARDS
- 2) SEALED ACRYLIC WINDOW
- 3) PADLOCK HASP AND STAPLE
- 4) ENCLOSURE SIDEWALLS ARE 14 GA CR STEEL
- 5) NEOPRENE GASKET
- 6) CONTINUOUS HINGE
- 7) SEE SHEET 2 OF 2 FOR EXTERNALLY-POWERED INTAKE FAN AND 120 Vac TERMINAL BLOCK
- 8) EXTERNAL FINISH IS ANSI-61 GRAY PAINT
- 9) SHIPPING WEIGHT IS APPROXIMATELY 120lb / 54kg ABOVE STANDARD CHARGER

DUAL DIMENSIONS in mm

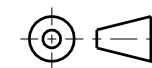

THIRD ANGLE PROJECTION

2	26643	062518	DRAWN BY MCR	040605	TITLE AT10.1 SERIES BATT CHGR CABINET OUTLINE: NEMA TYPE-4 (12/13) STYLE-5036 ENCLOSURE		
1	24875	052815	APPROVED GRB	040605	DRAWING No JE5073-00		
0	E2003	040605	UNLESS OTHERWISE NOTED DIMENSIONS ARE IN INCHES. TOLERANCES ARE:		REV 2	B	
REV	ECN No	DATE	SCALE NTS	PART No JE5073-00	SHEET 1	OF 2	

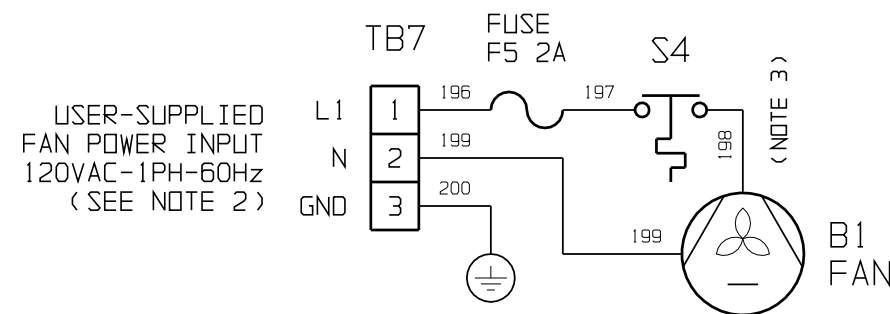
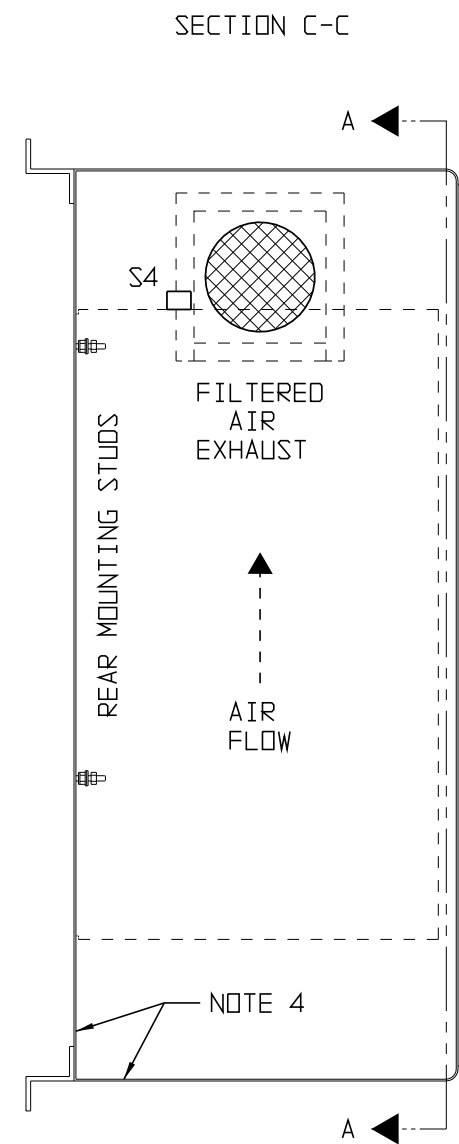
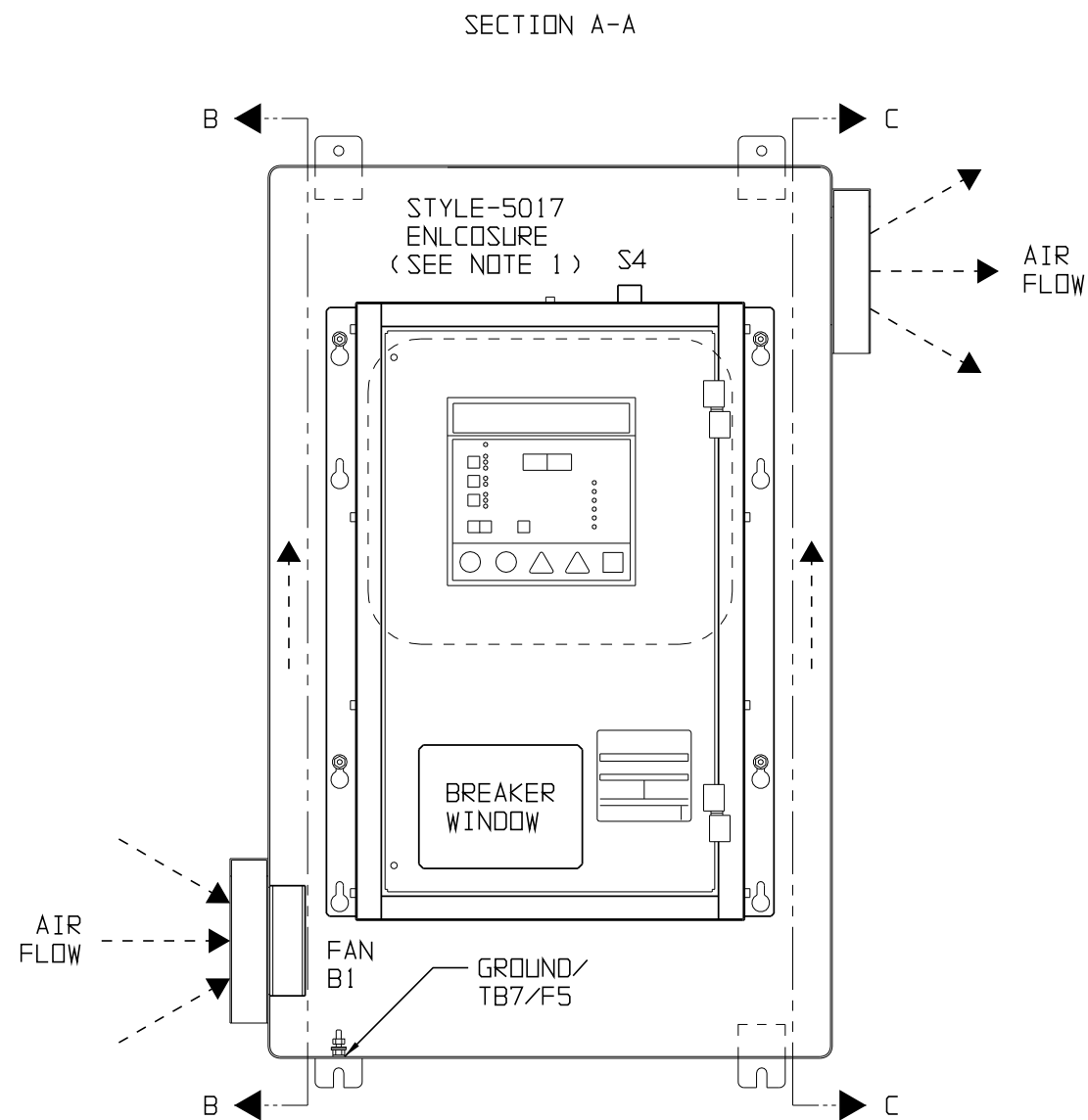
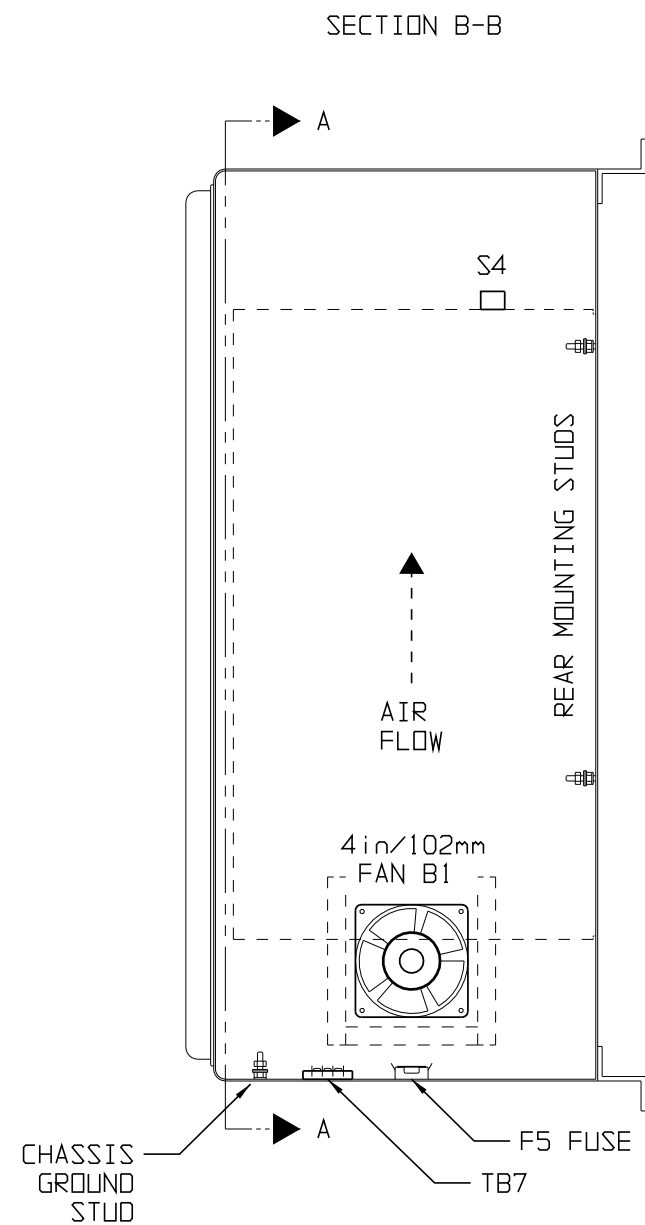

NOTES:

- 1) THIS DRAWING DEPICTS A NEMA TYPE 4 / IP66 ENCLOSURE, HOUSING A STANDARD NEMA-1 AT10.1 SERIES BATTERY CHARGER. SEE JE5025-00 FOR INTERNAL STYLE-5017 ENCLOSURE DIMENSIONS.
- 2) TB7 3-POS FAN EXTERNAL POWER TERMINAL BLOCK BARRIER TYPE, 6-32 BINDER HEAD SCREW TERMINAL, WILL ACCOMMODATE LUGS FOR #16-14 AWG WIRE.
- 3) VENTING FAN (B1) IS INTERMITTENT, ACTIVATED BY THERMAL SWITCH (S4), WHICH CLOSSES ON RISE AT 85°F / 29.4°C AND IS SELF-RESETTING.
- 4) ENCLOSURE INTERNAL FINISH IS SEMI-GLOSS WHITE.

WIRE LIST:

No.	FROM	TO	GA	COLOR
196	TB7-L1	F5-1	14	BLACK
197	F5-2	S4-1	14	BLACK
198	S4-2	B1-1	14	BLACK
199	B1-2	TB7-N	14	BLACK
200	TB7-GND	CHASSIS GROUND	12	GRN/YEL

		THIRD ANGLE PROJECTION	
DRAWN BY	MCR	040605	TITLE
APPROVED	GRB	040605	AT10.1 SERIES CABINET INTERNAL LAYOUT: NEMA-4 (12/13) STYLE-5036 ENCLOSURE
UNLESS OTHERWISE NOTED DIMENSIONS ARE IN INCHES. TOLERANCES ARE:		DRAWING No	REV
		JE5073-00	2
SCALE	NTS	PART No	SHEET
		JE5073-00	2 OF 2
			B