

HOLE	DIA.	QTY.	APPLICATION
A	0.438 11.11	4	FLOOR MOUNTING

NEMA-4/12/13 ENCLOSURES FEATURE NO PRE-FABRICATION PROVISIONS FOR CONDUIT ENTRANCE. CABINET SHOULD BE FIELD-MODIFIED BY INSTALLER AS NEEDED FOR I/O.

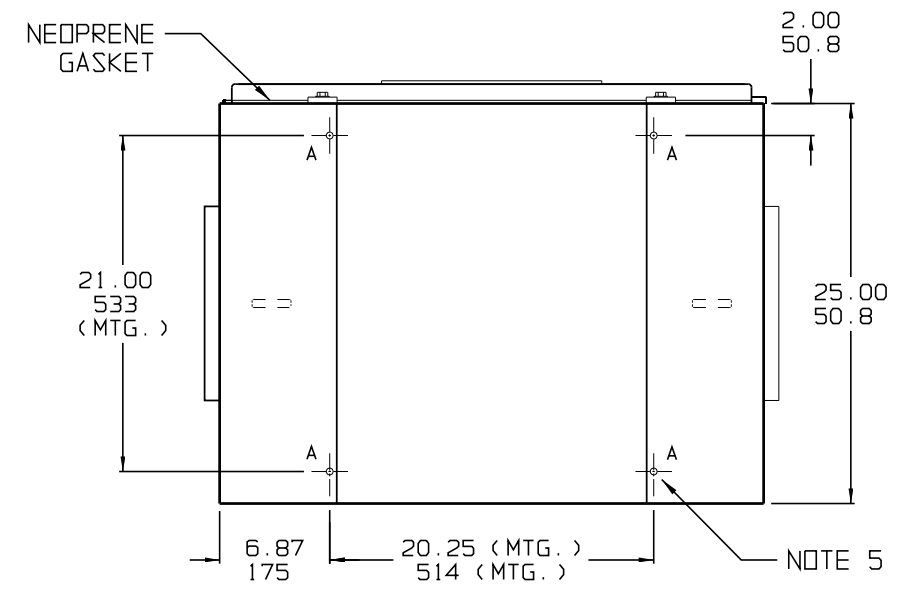
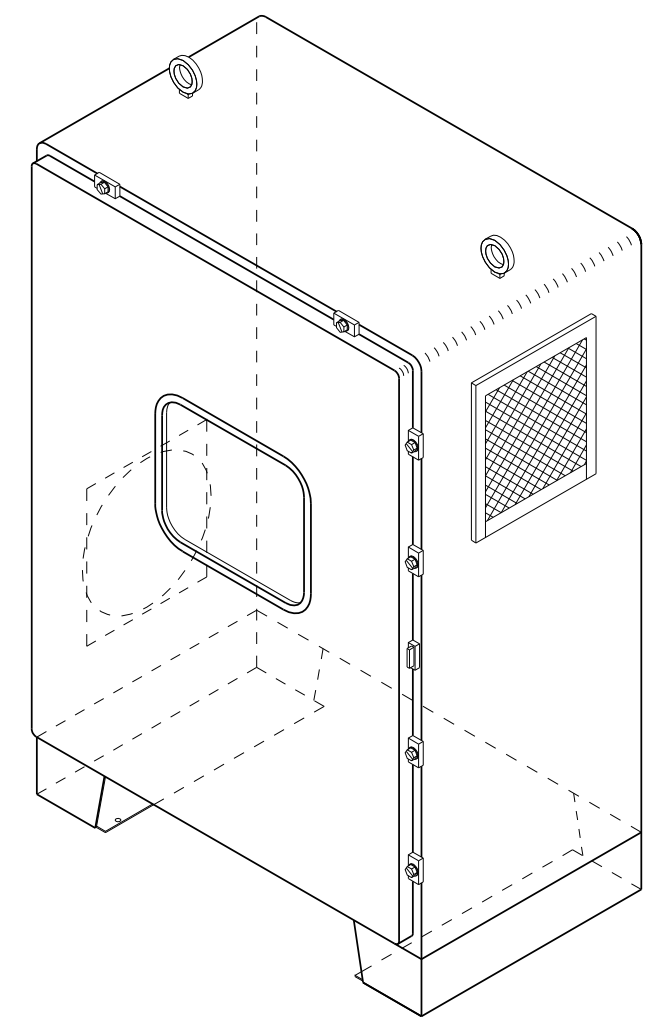

- NOTES:
- 1) DOOR CLAMPS SUPPLIED TO MEET NEMA TYPE 4 / IP66 ENCLOSURE STANDARDS
 - 2) ENCLOSURE FINISH IS ANSI-61 GRAY EPOXY POWDERCOAT
 - 3) SHIPPING WEIGHT IS APPROXIMATELY:
380lb / 172kg ABOVE STANDARD CHARGER WEIGHT
 - 4) ALLOW 12in / 305mm OF FREE AIR ON SIDES OF CABINET FOR VENTILATION
 - 5) UNIT IS FLOOR MOUNTED AND WIRED PER TABLE ABOVE
 - 6) SEE SHEET 2 OF 2 FOR EXTERNALLY-POWERED INTAKE FAN AND 120 Vac TERMINAL BLOCK
 - 7) ENCLOSURE SIDEWALLS ARE 12 GA CR STEEL

DUAL DIMENSIONS in mm

REV	ECN No	DATE	DRAWN BY MCR 040605		APPROVED GRB 042605		TITLE AT SERIES BATTERY CHARGER CABINET OUTLINE: NEMA TYPE 4 (12/13) STYLE-5037 ENCLOSURE	
2	24080	062518	DRAWN BY MCR 040605		APPROVED GRB 042605		TITLE AT SERIES BATTERY CHARGER CABINET OUTLINE: NEMA TYPE 4 (12/13) STYLE-5037 ENCLOSURE	
1	24080	022814	DRAWN BY MCR 040605		APPROVED GRB 042605		TITLE AT SERIES BATTERY CHARGER CABINET OUTLINE: NEMA TYPE 4 (12/13) STYLE-5037 ENCLOSURE	
0	E2003	040605	DRAWN BY MCR 040605		APPROVED GRB 042605		TITLE AT SERIES BATTERY CHARGER CABINET OUTLINE: NEMA TYPE 4 (12/13) STYLE-5037 ENCLOSURE	
UNLESS OTHERWISE NOTED DIMENSIONS ARE IN INCHES. TOLERANCES ARE:			DRAWING No		REV		B	
			JE5074-00		2			
			SCALE NTS		PART No JE5074-00		SHEET 1 OF 2	

SECTION B-B

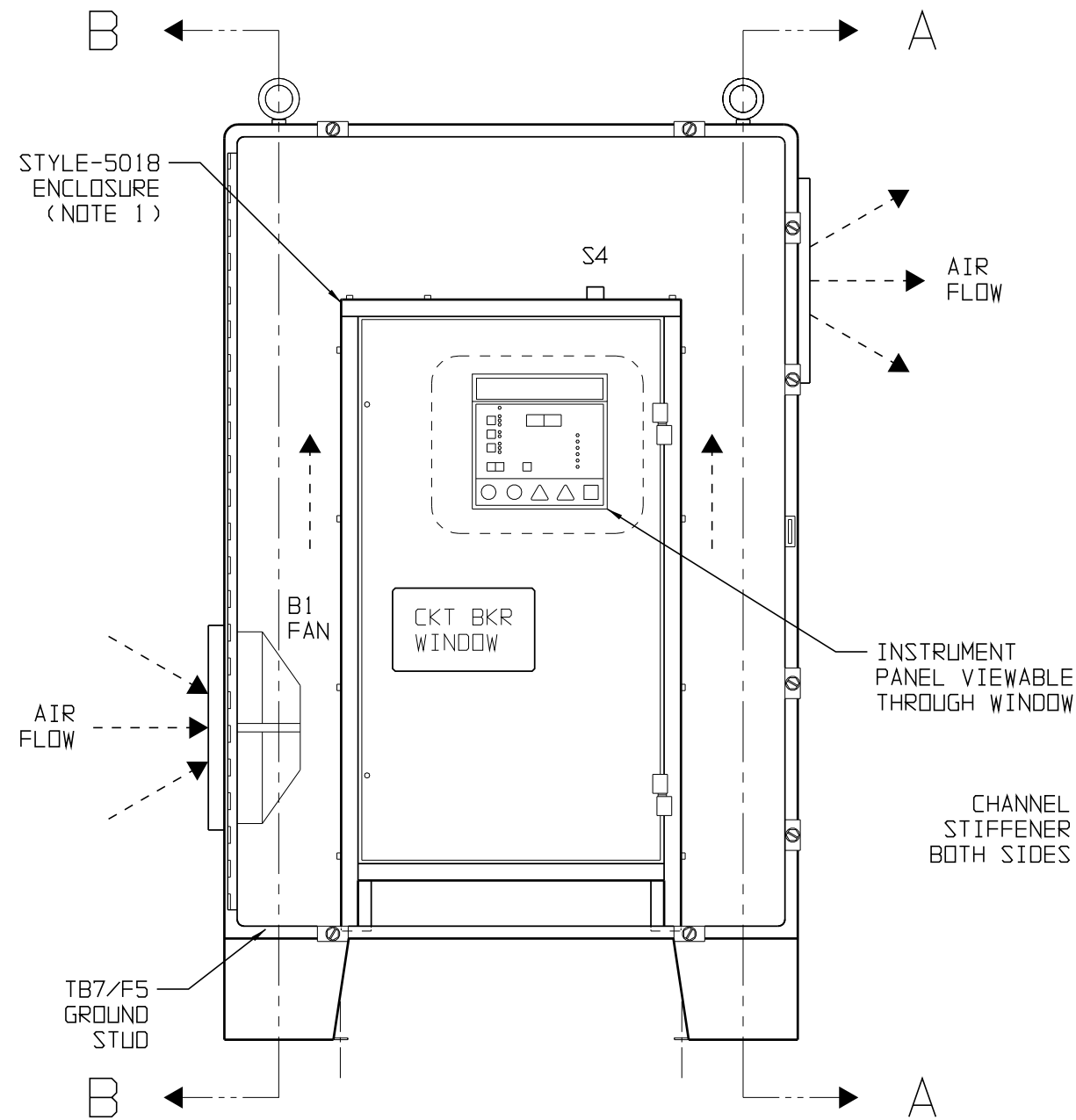
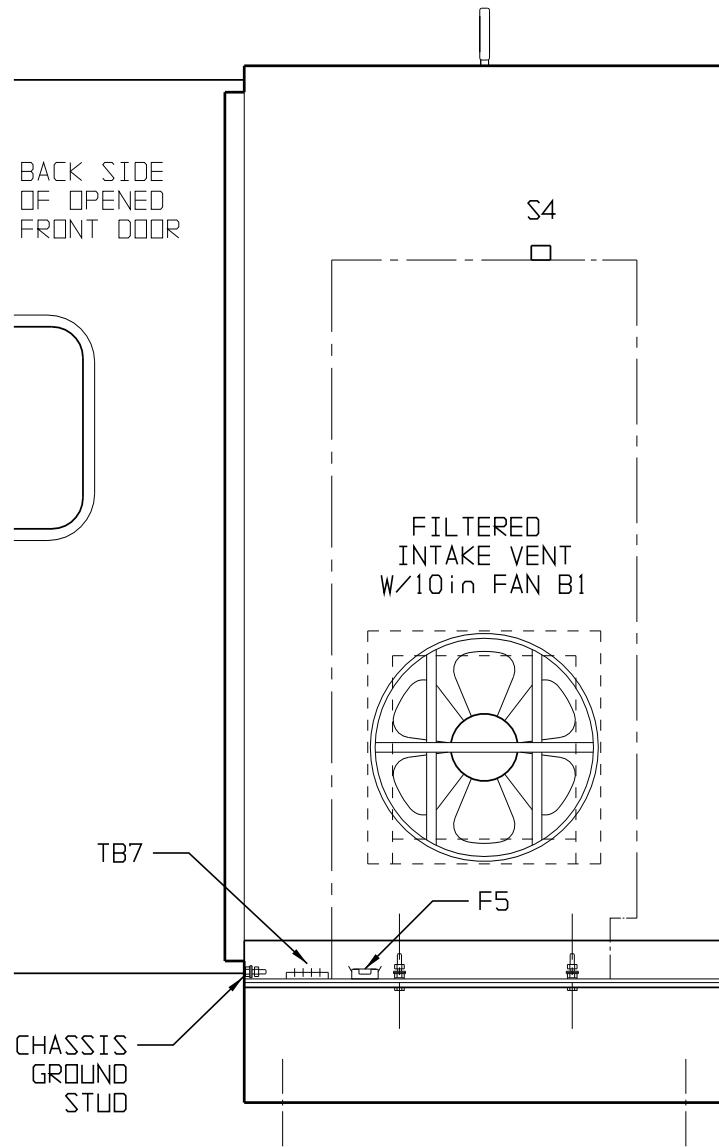

SECTION A-A

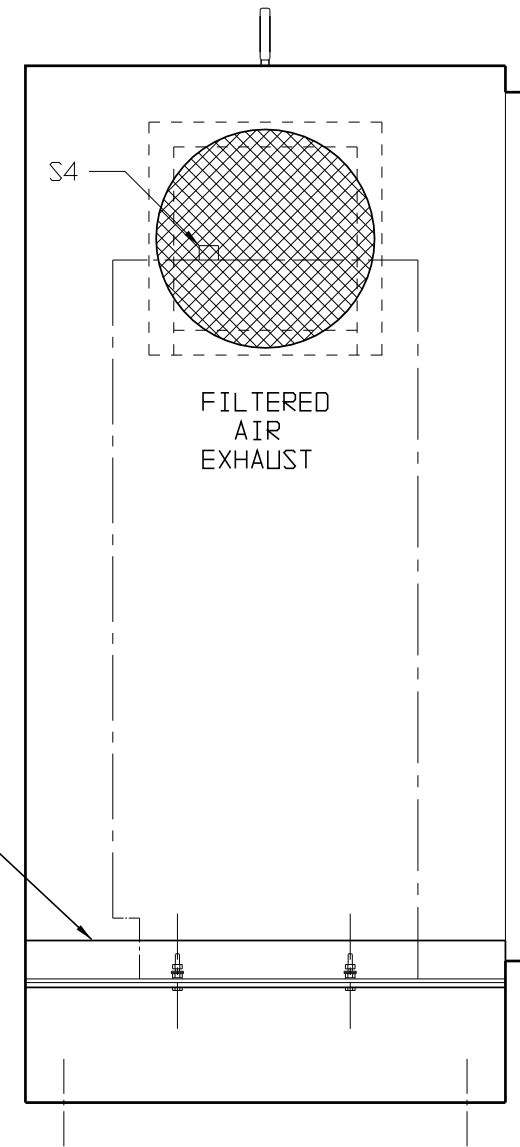

USER-SUPPLIED
FAN POWER INPUT
120VAC-1PH-60Hz
(SEE NOTE 2)

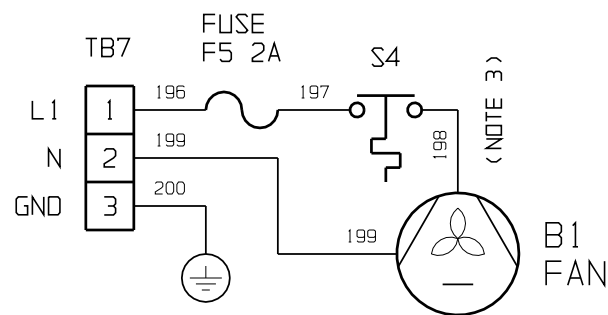

NOTES:

- 1) THIS DRAWING DEPICTS A NEMA TYPE 4 / IP66 CABINET, HOUSING A STANDARD NEMA-1 AT SERIES BATTERY CHARGER. SEE JE5026-00 OR JE5085-00 FOR INTERNAL STYLE-5018 ENCLOSURE DIMENSIONS.
- 2) TB7 3-POS FAN EXTERNAL POWER TERMINAL BLOCK BARRIER TYPE, 6-32 BINDER HEAD SCREW TERMINAL, WILL ACCOMMODATE LUGS FOR #22-14 AWG WIRE.
- 3) VENTING FAN (B1) IS INTERMITTENT, ACTIVATED BY THERMAL SWITCH (S4), WHICH CLOSES ON RISE AT 85 °F / 29.4 °C, AND IS SELF-RESETTING.
- 4) ENCLOSURE INTERNAL FINISH IS SEMI-GLOSS WHITE.

WIRE LIST:

No.	FROM	TO	GA	COLOR
196	TB7-L1	F5-1	14	BLACK
197	F5-2	S4-1	14	BLACK
198	S4-2	B1-1	14	BLACK
199	B1-2	TB7-N	14	BLACK
200	TB7-GND	CHASSIS GROUND	12	GRN/YEL

 THIRD ANGLE PROJECTION		TITLE AT SERIES CHGR CABINET INTERNAL LAYOUT: NEMA TYPE-4 (12/13) STYLE-5037 ENCLOSURE	
DRAWN BY MCR APPROVED GRB	040605 042605	DRAWING No JE5074-00	REV 2 B
SCALE NTS	PART No JE5074-00	SHEET 2 OF 2	