

HOLE	DIA.	QTY.	APPLICATION
A	0.438 11.11	4	FLOOR MOUNTING

NEMA-4/12/13 ENCLOSURES FEATURE NO PRE-FABRICATION PROVISIONS FOR CONDUIT ENTRANCE. CABINET SHOULD BE FIELD-MODIFIED BY INSTALLER AS NEEDED FOR I/O.

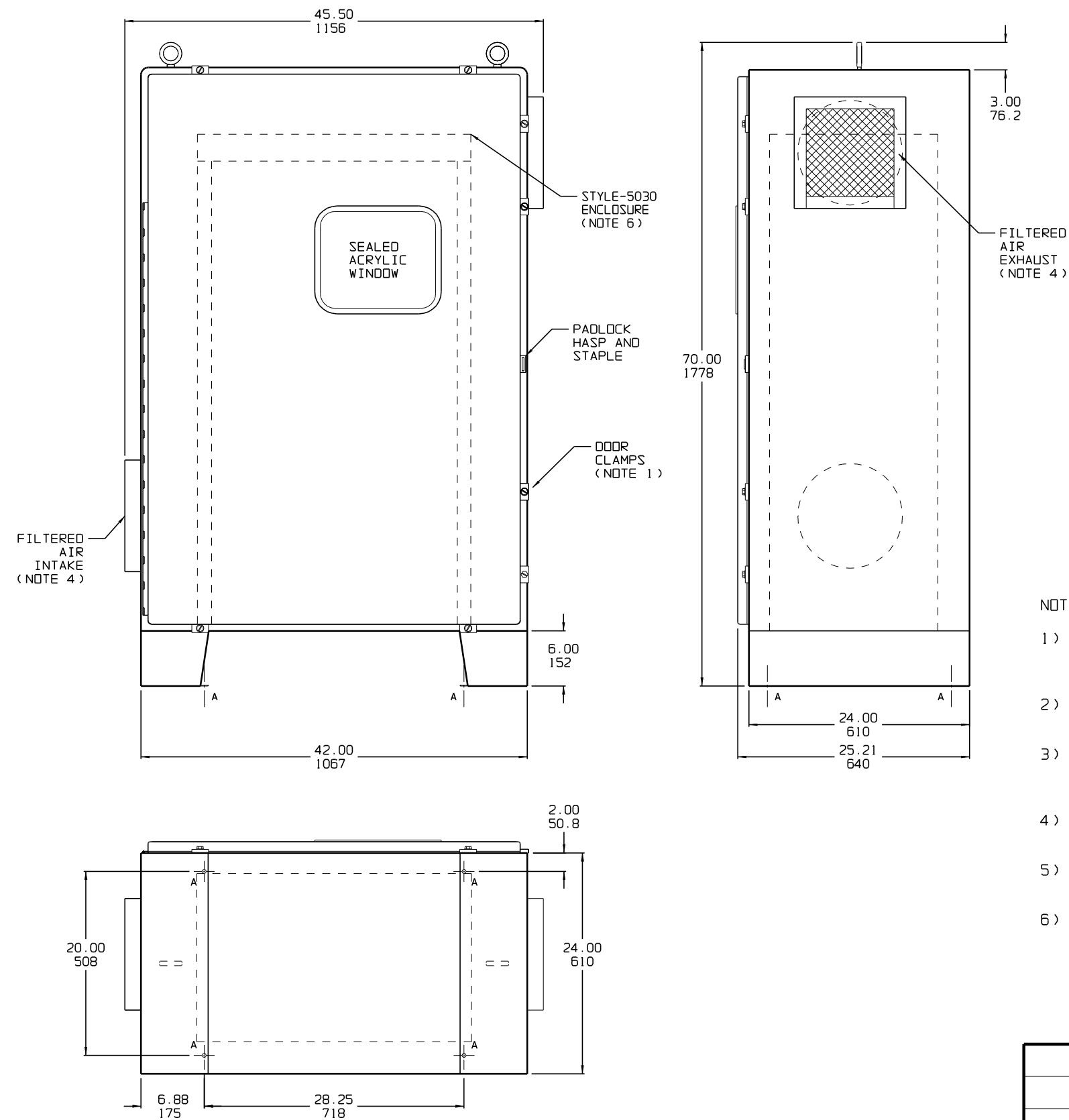

- NOTES:
- 1) DOOR CLAMPS AND GASKETS SUPPLIED TO MEET NEMA-4/12/13 ENCLOSURE STANDARDS.
  - 2) ENCLOSURE FINISH IS ANSI-61 GRAY EPOXY POWDERCOAT.
  - 3) ENCLOSURE (NOT INCLUDING INTERNAL CHARGER) APPROXIMATE SHIPPING WEIGHT: 360 lbs / 16 kg
  - 4) ALLOW 12in / 305mm OF FREE AIR ON SIDES OF CABINET FOR VENTILATION.
  - 5) UNIT IS FLOOR MOUNTED AND WIRED PER TABLE ABOVE.
  - 6) SHEE SHEET 2 OF 2 FOR INTERNAL CONFIGURATION.

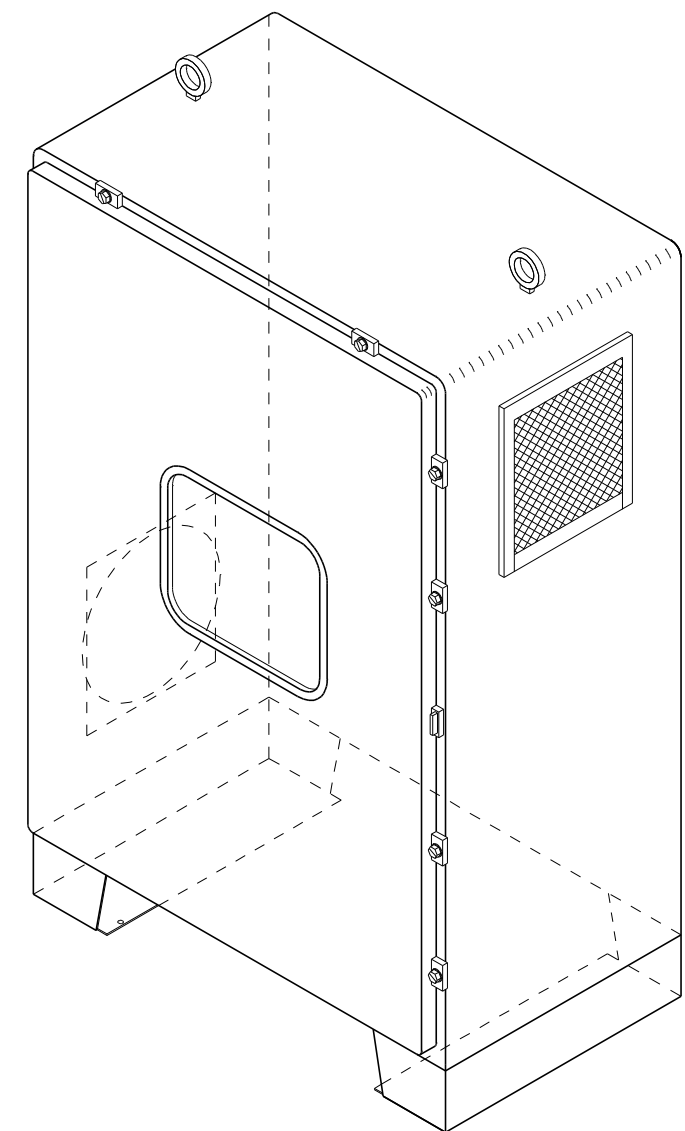

DUAL DIMENSIONS in mm

			THIRD ANGLE PROJECTION					
			DRAWN BY MCR 120208		TITLE AT30 SERIES BATTERY CHARGER OUTLINE: NEMA-4 (12/13) ENCLOSURE - ST-5057 CABINET			
1	24076	123013	ELECTRONIC APPROVAL SIGNATURES MAINTAINED BY MFG ECN LOG		DRAWING No JE5108-00		REV 1	<b>B</b>
0	21438	120208	UNLESS OTHERWISE NOTED DIMENSIONS ARE IN INCHES. TOLERANCES ARE:		SCALE NTS		PART No JE5108-00	SHEET 1 OF 2
REV	ECN No	DATE						

# SECTION B-B

# SECTION A-A

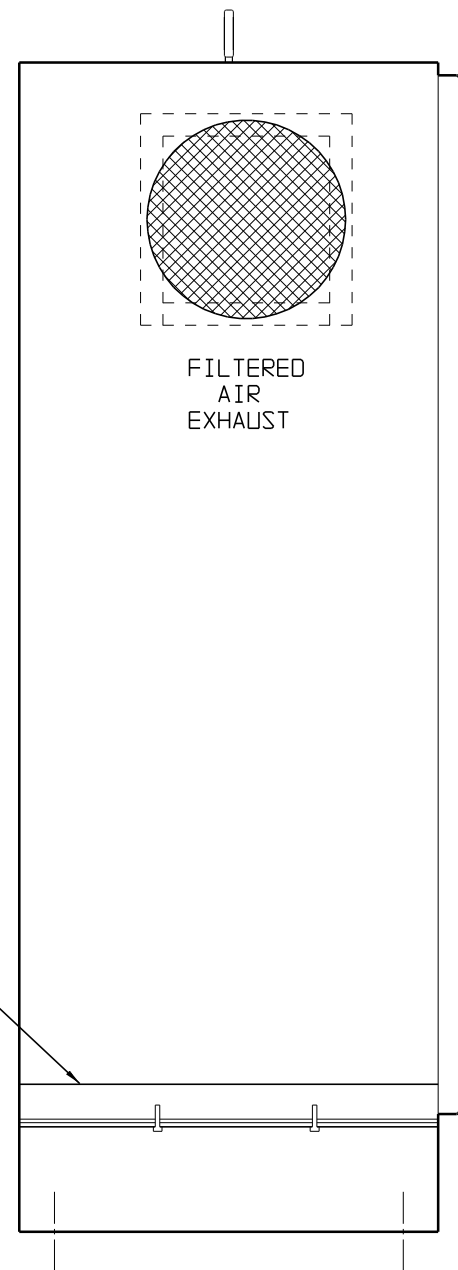
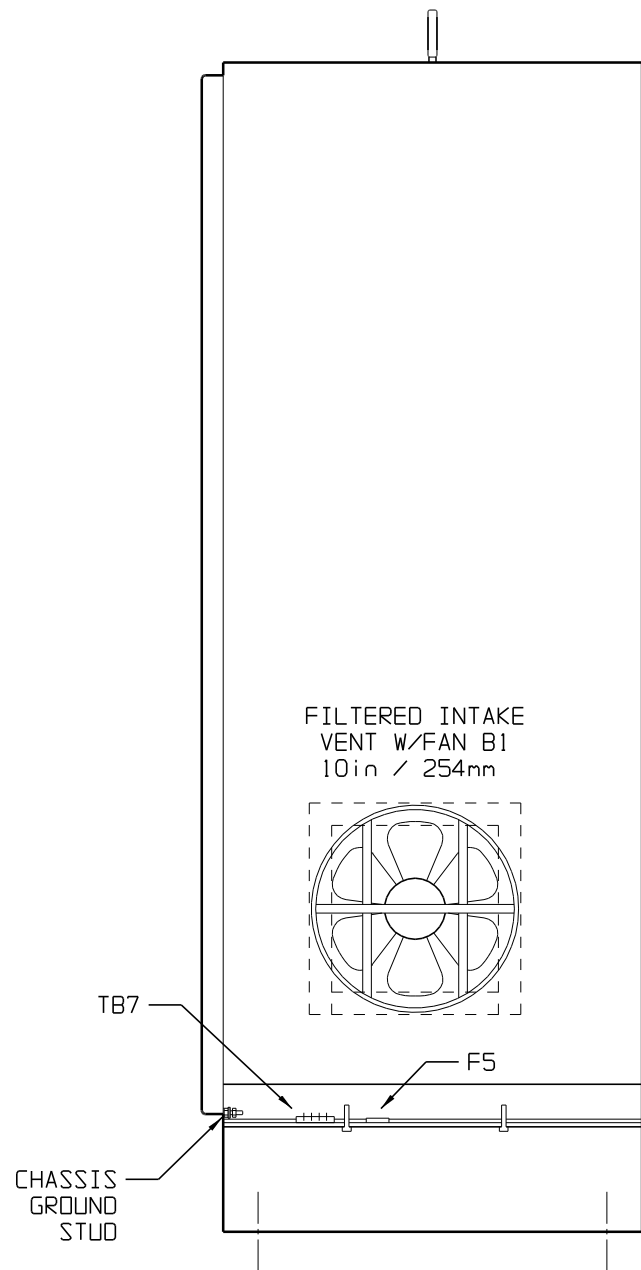
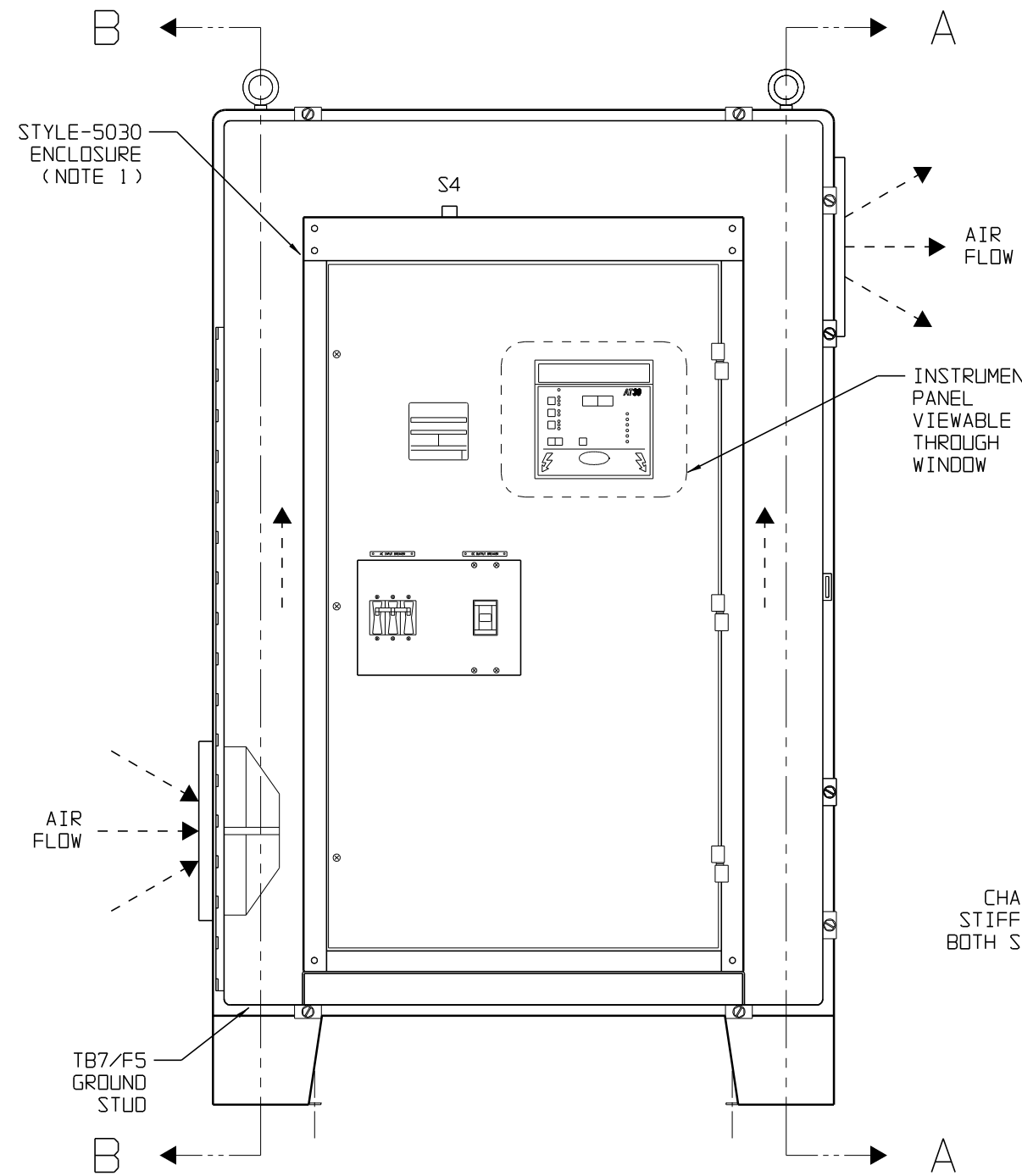

WIRE LIST:

No.	FROM	TO	GA	COLOR
196	TB7-L1	F5-1	14	BLACK
197	F5-2	S4-1	14	BLACK
198	S4-2	B1-1	14	BLACK
199	B1-2	TB7-N	14	BLACK
200	TB7-GND	CHASSIS GROUND	12	GRN/YEL

NOTES:

- THIS DRAWING DEPICTS A NEMA TYPE 4 ENCLOSURE, HOUSING A STANDARD NEMA-1 AT30 SERIES BATTERY CHARGER. SEE JE5086-00 FOR INTERNAL STYLE-5030 ENCLOSURE DIMENSIONS.
- TB7 3-POS FAN EXTERNAL POWER TERMINAL BLOCK BARRIER TYPE, 6-32 BINDER HEAD SCREW TERMINAL, WILL ACCOMMODATE LUGS FOR #16-14 AWG WIRE.
- VENTING FAN (B1) IS INTERMITTENT, ACTIVATED BY THERMAL SWITCH (S4), WHICH CLOSES ON RISE AT 120°F / 48.9°C AND IS SELF-RESETTING.
- ENCLOSURE INTERNAL FINISH IS SEMI-GLOSS WHITE.

USER-SUPPLIED FAN POWER INPUT 120VAC-1PH-60Hz (SEE NOTE 2)

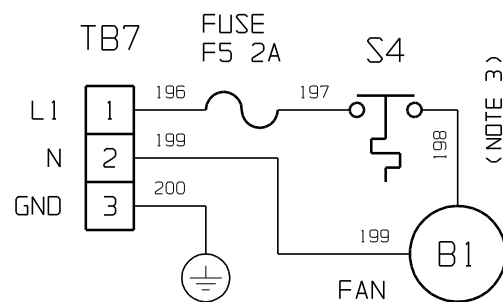

<p>THIRD ANGLE PROJECTION</p>		<p>TITLE AT30 SERIES BATTERY CHARGER OUTLINE: NEMA-4 (12/13) ENCLOSURE - ST-5057 CABINET</p>	
<p>DRAWN BY MCR 120208</p>	<p>DRAWING No. JE5108-00</p>		<p>REV 1</p>
<p>ELECTRONIC APPROVAL SIGNATURES MAINTAINED BY MFG ECN LOG</p>		<p>SCALE NTS</p>	<p>PART No. JE5108-00</p>
<p>UNLESS OTHERWISE NOTED DIMENSIONS ARE IN INCHES. TOLERANCES ARE:</p>		<p>SHEET 2 OF 2</p>	<p><b>B</b></p>