

NOTES:

- 1) SCR/SCRF SERIES STYLE-1B ENCLOSURE SHOWN. STYLE-1A ENCLOSURE MOUNTS SIMILARLY. OVERALL HEIGHT OF MOUNTED UNITS:
39.00in (STYLE-1A)
50.25in (STYLE-1B)
- 2) FOR FIELD INSTALLATION, TRANSFER DRILL 0.281in DIA. HOLES INTO SIDE OF CABINET, THREE (3) PER SIDE.
- 3) IF FACTORY INSTALLED, MOUNTING HOLES ARE PRE-DRILLED INTO SIDE OF ENCLOSURE. BRACKETS NOT SHIPPED ATTACHED TO UNIT.
- 4) MOUNT FLOOR BRACKETS TO CHARGER WITH SUPPLIED HARDWARE.
- 5) FOR SAFE OPERATION OF UNIT, CHARGER/ BRACKET ASSEMBLY MUST BE ANCHORED TO FLOOR (FLOOR-MTG. HARDWARE NOT SUPPLIED WITH ASSEMBLY).

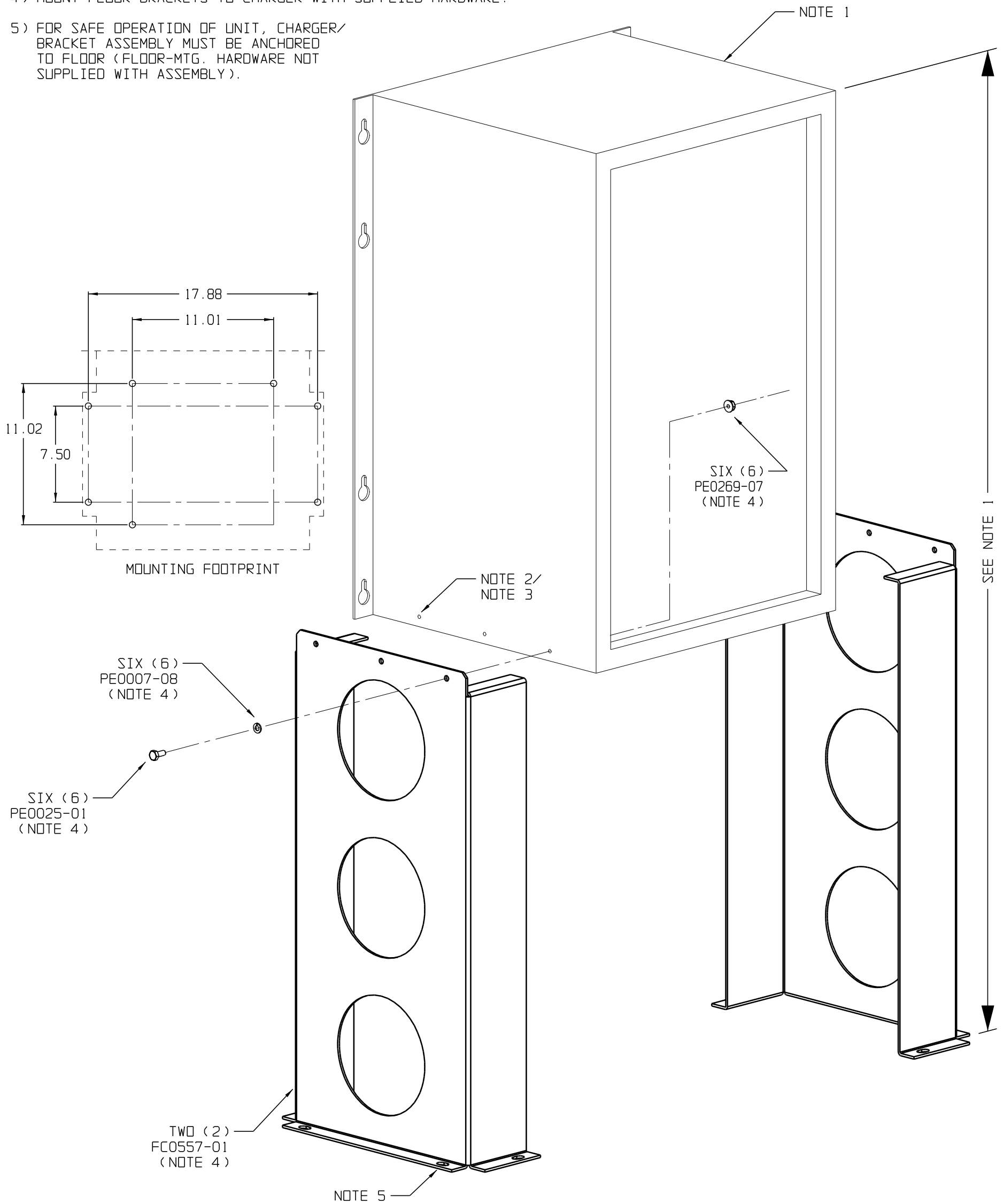

			THIRD ANGLE PROJECTION		TITLE E10184-03 24in FLOOR MTG BRACKET ASSY: SCR/SCRF SERIES STYLE-1A/1B ENCLOSURES		
			DRAWN BY MCR 090210	DRAWING No JE5123-00			REV A
			ELECTRONIC APPROVAL SIGNATURES MAINTAINED BY MFG ECN LOG		SHEET 1 OF 1		
A	N/A	090210	UNLESS OTHERWISE NOTED DIMENSIONS ARE IN INCHES. TOLERANCES ARE:		PART No JE5123-00		
REV	ECN No	DATE			SCALE	NTS	