

| PART No.  | VOLTAGE RATING | CURRENT RATING |
|-----------|----------------|----------------|
| EJ5144-01 | 250 VDC        | 100 ADC        |
| EJ5144-05 | 600 VDC        | 100 ADC        |

NOTES:

- 1) ENCLOSURE IS A NEMA-1 TYPE STEEL CABINET WITHOUT GASKETS, FINISH IS ANSI-61 GRAY EPOXY POWDERCOAT.
- 2) ALLOW 6in OF FREE AIR ON TOP, SIDES AND BOTTOM OF CABINET FOR VENTILATION.
- 3) STANDARD PRE-FAB SIDE CONDUIT KNOCK-OUTS SHOWN, ENCLOSURE MAY BE FIELD-MODIFIED BY INSTALLER IF REQUIRED.
- 4) STEERING DIODE ASSEMBLY SHIPPING WEIGHT: APPROXIMATELY 120 lb / 54 kg

FUNCTION:

- A) STEERING DIODES LINK TWO (2) BATTERY CHARGER DC OUTPUT BUSES TO COMMON LOAD WITHOUT LINKING BATTERY BANKS TOGETHER. SEE OPERATING INSTRUCTIONS (JA5065-00).

TOP VIEW

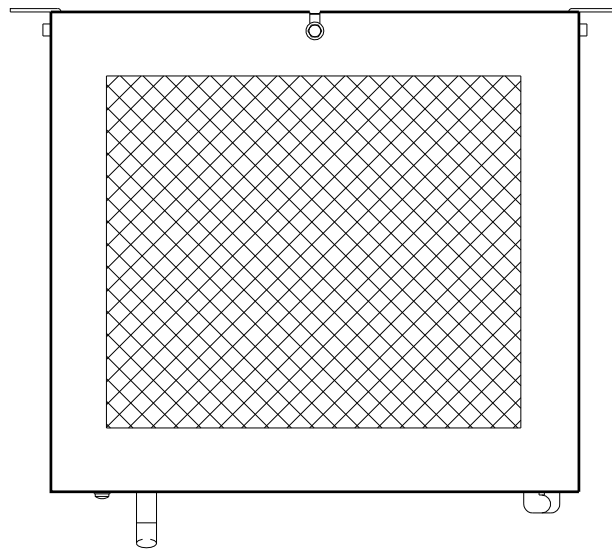

FRONT VIEW

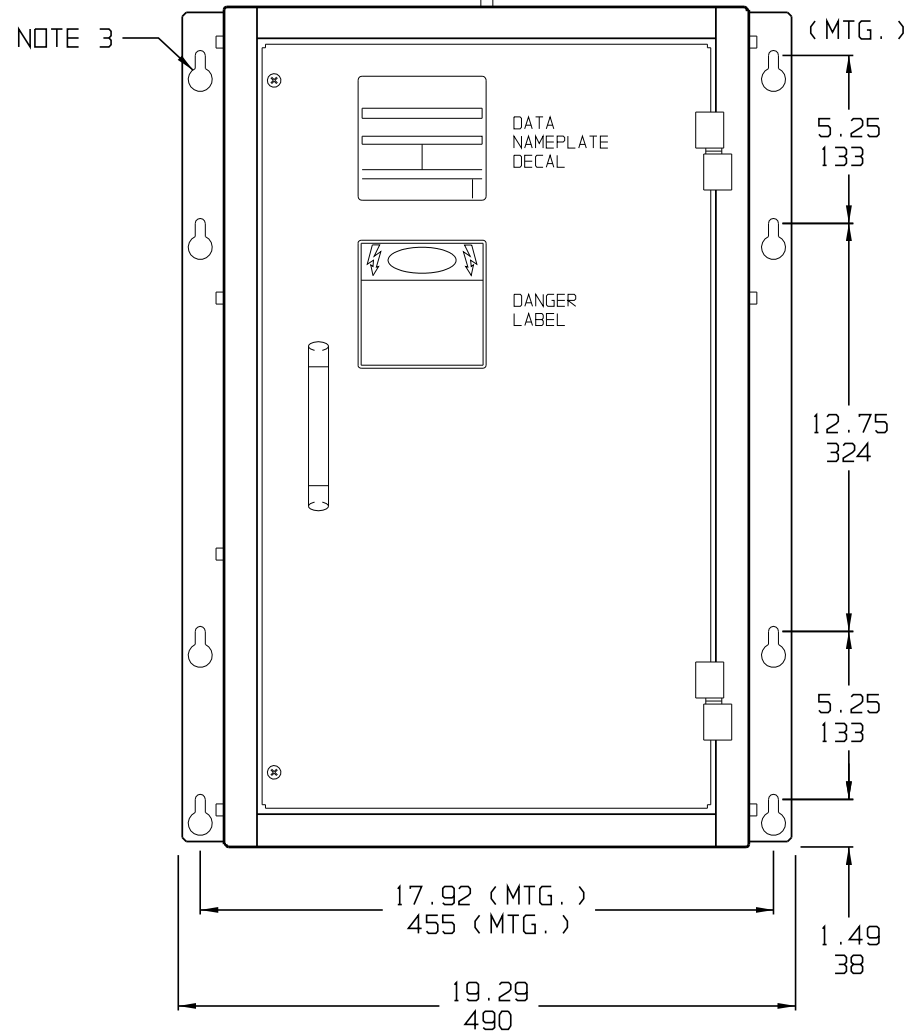

SIDE VIEW

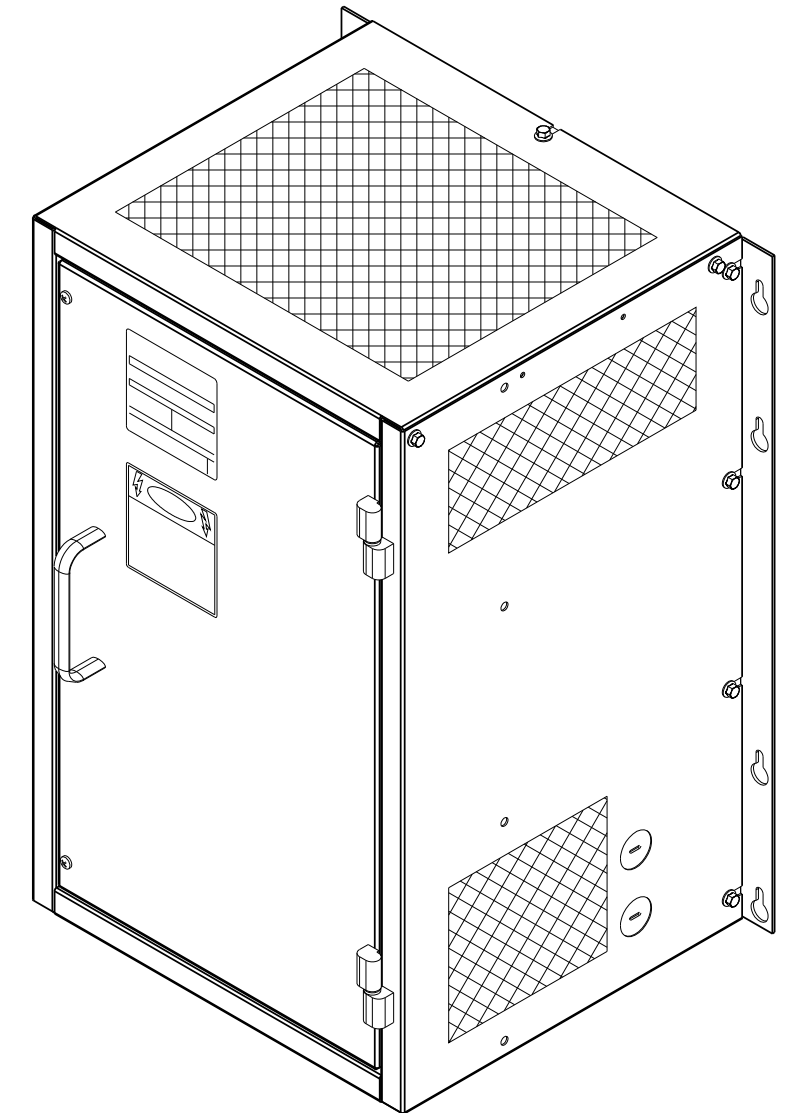
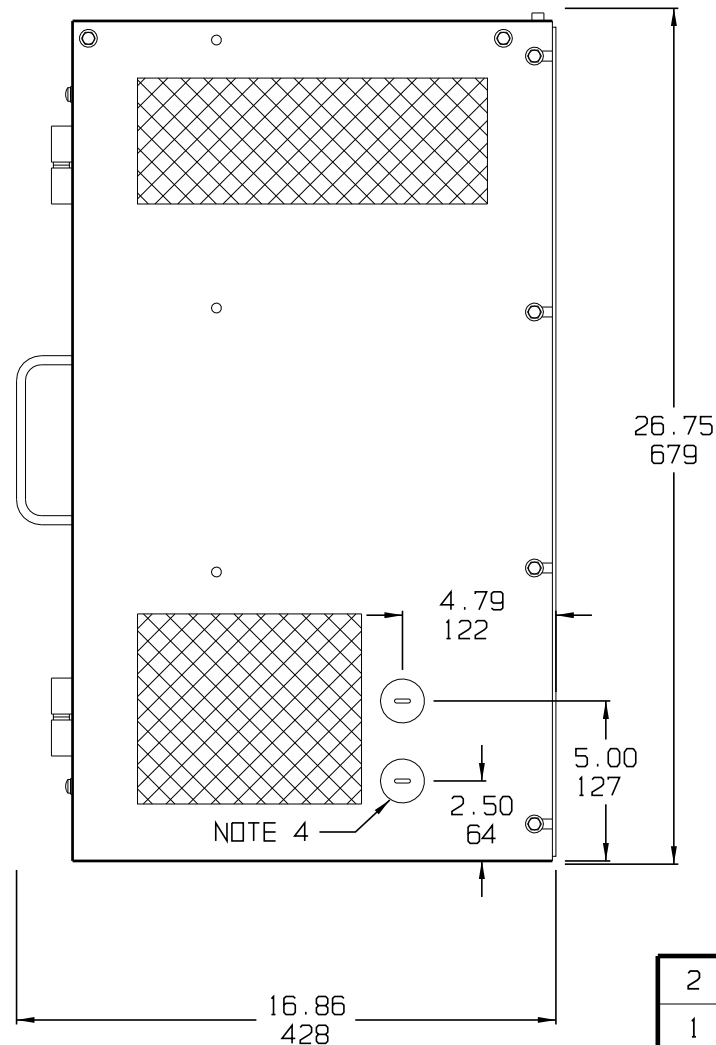

DUAL DIMENSIONS in mm

|     |        |        |  |  |  |  |
|-----|--------|--------|--|--|--|--|
| 2   | 27441  | 021720 | <br>THIRD ANGLE PROJECTION                                       | TITLE BEST BATTERY SELECTOR OUTLINE:<br>NEMA-1 STYLE-5017 ENCLOSURE (100A) |  |  |
| 1   | 24624  | 102714 |  |  |  |  |
| 0   | 23735  | 052913 | DRAWN BY MCR 093010  | DRAWING No JE5138-01 REV 2 <b>B</b>  |  |  |
| D   | N/A    | 062609 | ELECTRONIC APPROVAL SIGNATURES MAINTAINED BY MFG ECN LOG         |  |  |  |
| A   | N/A    | 082106 | UNLESS OTHERWISE NOTED DIMENSIONS ARE IN INCHES. TOLERANCES ARE: | SCALE NTS PART No JE5138-01 SHEET 1 OF 1                                   |  |  |
| REV | ECN No | DATE   |  |  |  |  |