

NOTES:

- ALL WIRING SHOULD CONFORM TO NEC, LOCAL, AND SITE CODES. USE ONLY COPPER (CU) CONDUCTORS.
- MAIN DIRECT FEED (TOP)
 - TWO (2) IlSCO CU-AL COMPRESSION BOX LUGS
 - EACH ACCEPTING #6 TO 350 MCM WIRE
- BRANCH BREAKERS (CB5x)
 - Square-D PowerPact Bx2-FRAME
 - COMPRESSION LUGS, ACCEPTING #14 TO 3/0 AWG
- CU-AL GROUND COMPRESSION BOX LUG TERMINAL
 - ACCEPTING #14 TO 1/0 AWG WIRE
- COPPER BUS BARS SUPPLIED FOR EASE OF BRANCH CIRCUIT BREAKER INSTALLATION.
- REAR WALL-MOUNTING HOLES, SEE JE5368-38 FOR EXTERNAL MOUNTING DETAILS.
- ALL BREAKERS (MAIN FEEDER & DISTRIBUTION) ARE LISTED TO STANDARD UL 489.
- FOR FURTHER DETAILS, SEE DCP OPERATING INSTRUCTIONS (JA5117-01).

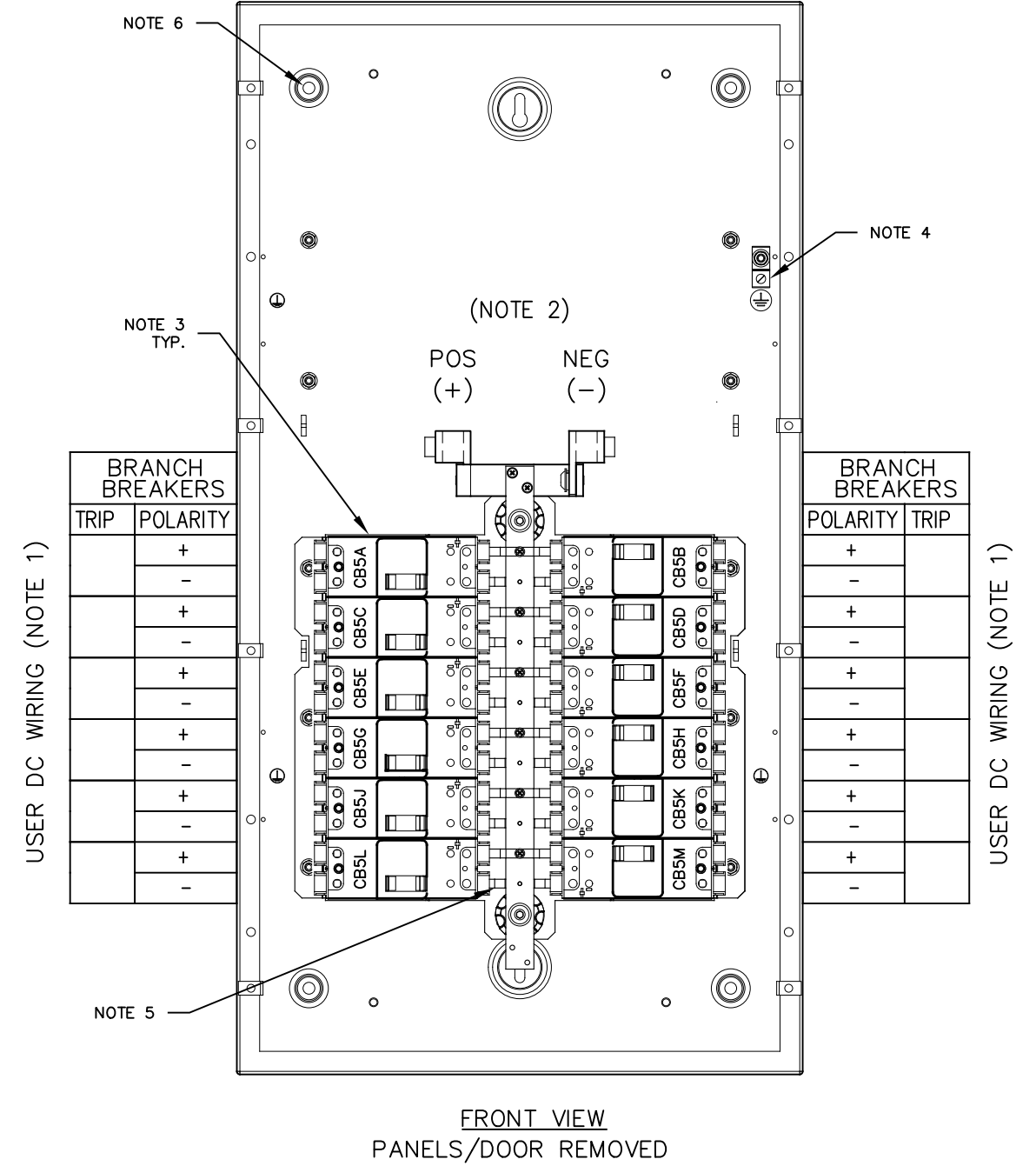
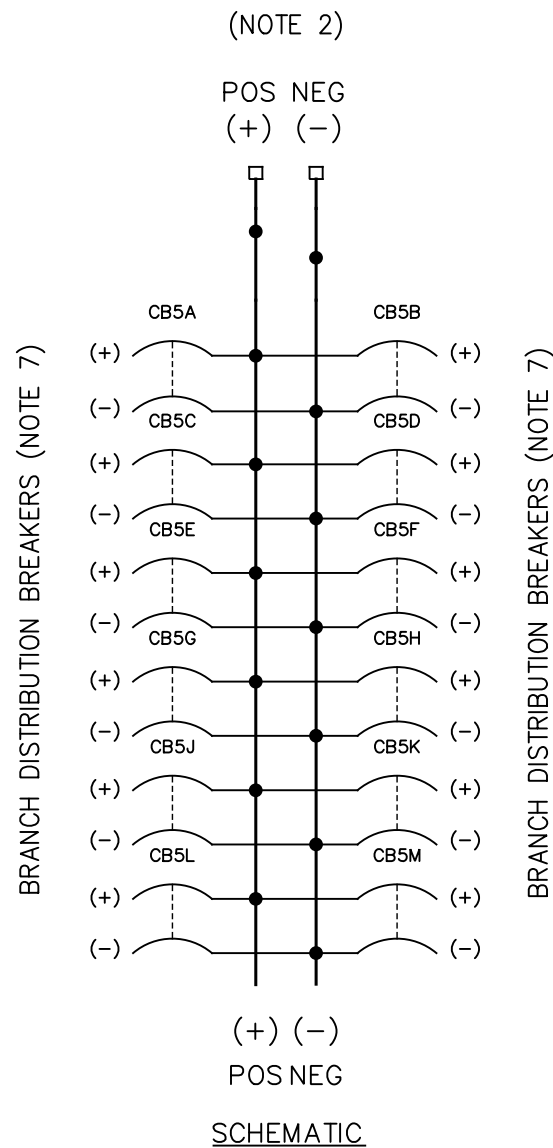

REV	DRN BY	CHK BY	APP BY	DATE	DRN BY	DATE	TITLE DC CONTROL PANEL INTERNAL COMPONENT LAYOUT DRAWING STYLE-5013 MH38 - DIRECT DC LUGS			
0	MCR	n/a	n/a	01.17.2024	MCR	01.17.2024				
DESCRIPTION REV. 0: INITIAL RELEASE										
					CHK BY	DATE				
					n/a	01.17.2024				
					APP BY	DATE				
					n/a	01.17.2024				
NOTICE										
• UNCONTROLLED DOCUMENT										
• CHANGES / DIGITAL SIGNATURES MAINTAINED BY MANUFACTURER										
THIRD ANGLE PROJECTION					SIZE	SCALE	DWG No	REV	SHEET	
					B	NTS	JE5369-30	0	1 OF 1	